

Standard dosing system for Icing Sugar

Based on 55 years' experience and knowledge in **Mechanical Flexible Conveying technology** for all powders, SUGAR INPROCESS has developed a special **easy to build standard equipment** for icing sugar dosing. No air, no bearings, no filters, but a flexible and resistant stainless steel spring.

The ISD series are especially designed with a flat bottom with anti-bridging device to be connected to a cylindrical hopper and dose icing sugar to a mixing tank or a packaging machine for example.

This time-tried system in all configurations is easy to set-up and support, easy to connect and start.

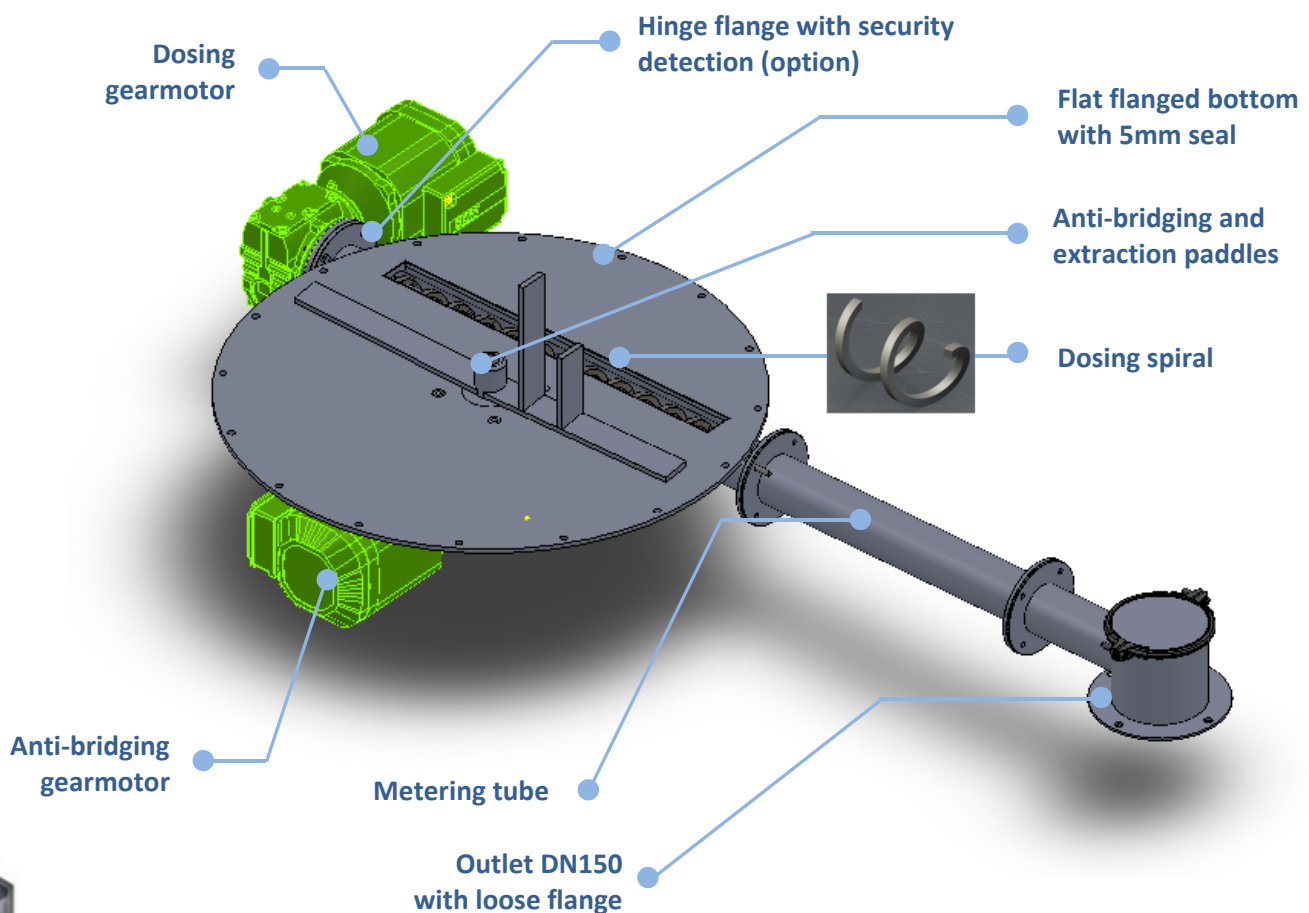

This unit works easily connected beneath standard hoppers capacity 150 / 300 / 500 liters or with special connection beneath silos, mixers, bulk bags discharging station



TECHNICAL DIAGRAM

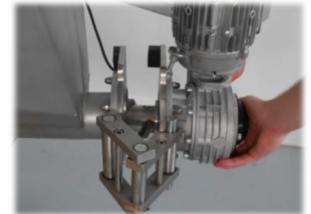
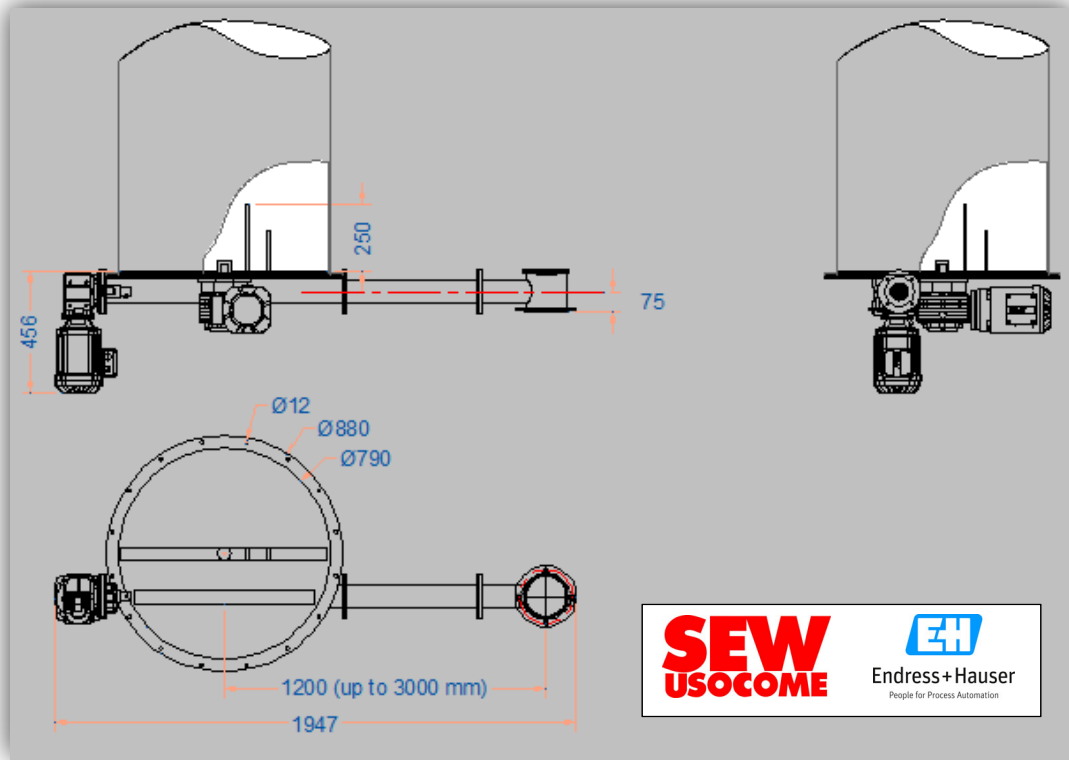

In option, the dosing gearmotor can be connected with hinge flange with security detection for a quick and easy cleaning and a complete dismantling of the dosing spiral.

EXAMPLES



Icing sugar
Snow Sugar
Cocoa Powder
Starch...

